

# TUBE CLEANING

Fully integrated systems for single, dual and triple flex lance exchanger tube cleaning. Designed to increase safety and maximize productivity.

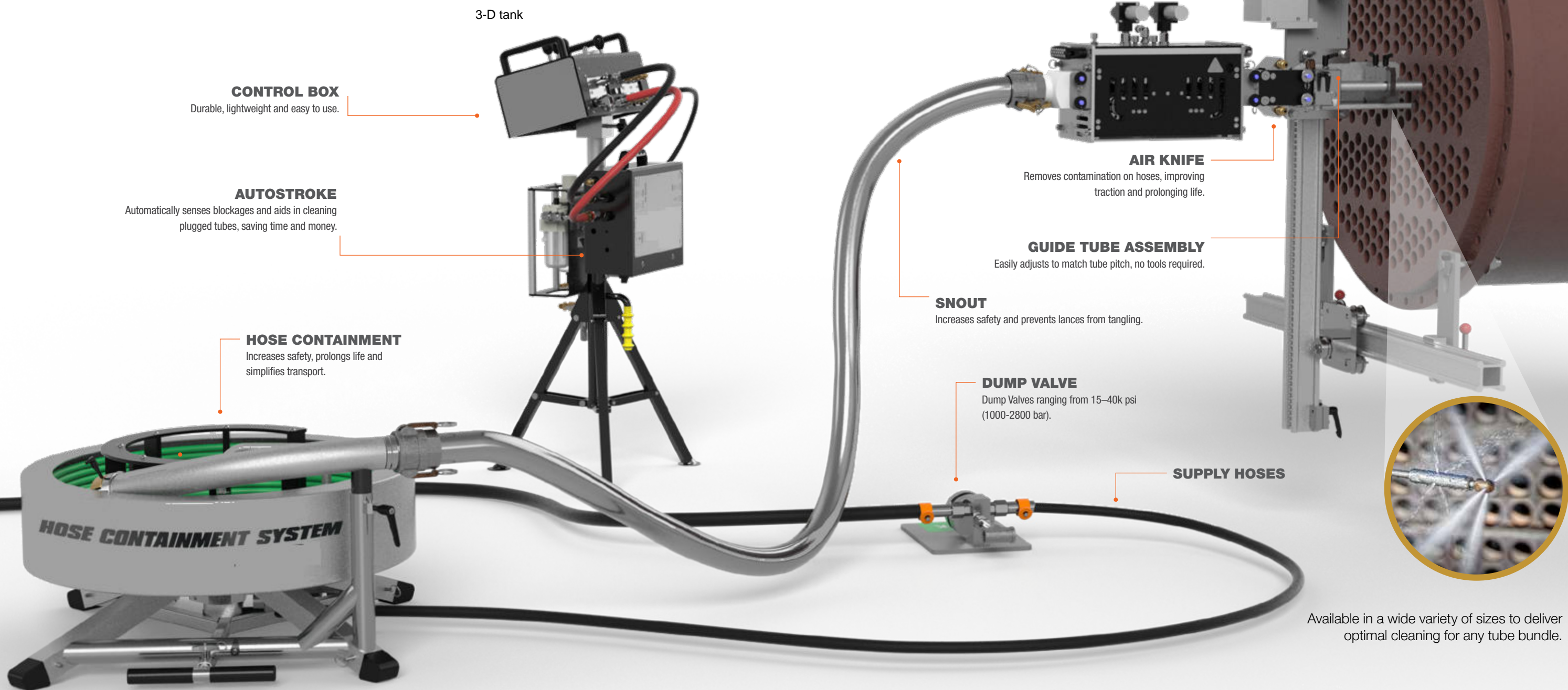

**CONTROL BOX**  
Durable, lightweight and easy to use.

**AUTOSTROKE**  
Automatically senses blockages and aids in cleaning plugged tubes, saving time and money.

**HOSE CONTAINMENT**  
Increases safety, prolongs life and simplifies transport.

3-D tank

**LIGHTWEIGHT POSITIONER**  
Versatile, portable and quick to setup.

**HOSE TRACTOR**  
Intuitive to use and dependable in extreme conditions.

**AIR KNIFE**  
Removes contamination on hoses, improving traction and prolonging life.

**GUIDE TUBE ASSEMBLY**  
Easily adjusts to match tube pitch, no tools required.

**SNOUT**  
Increases safety and prevents lances from tangling.

**DUMP VALVE**  
Dump Valves ranging from 15–40k psi (1000-2800 bar).

**SUPPLY HOSES**



Available in a wide variety of sizes to deliver optimal cleaning for any tube bundle.



# PIPE CLEANING

Complete systems to automate the cleaning of industrial pipes and drains. Designed for adaptability in a wide range of applications for straight and curved pipes in all sizes.



## MULTIPLE MOUNTING OPTIONS

For pipes with or without a flange

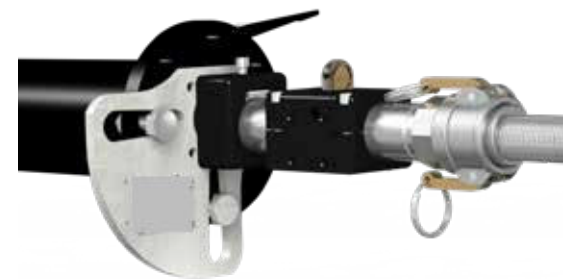

### FLANGE MOUNT

Versatile mount with cam-lock attachment for quick setup.

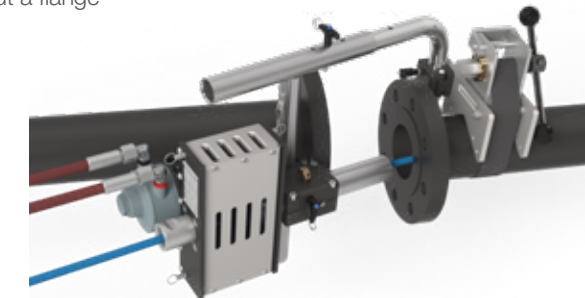

### STRAP MOUNT

For pipes without a flange or off-axis mounting.

### CONTROL BOX

Lightweight, durable and easy to use.

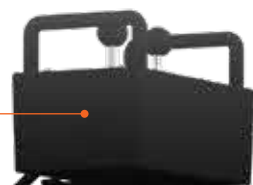

### FLEX LANCES

Flex Lances ranging from 15-40k.



### HOSE TRACTOR

Intuitive to use, inexpensive to maintain and extremely versatile.

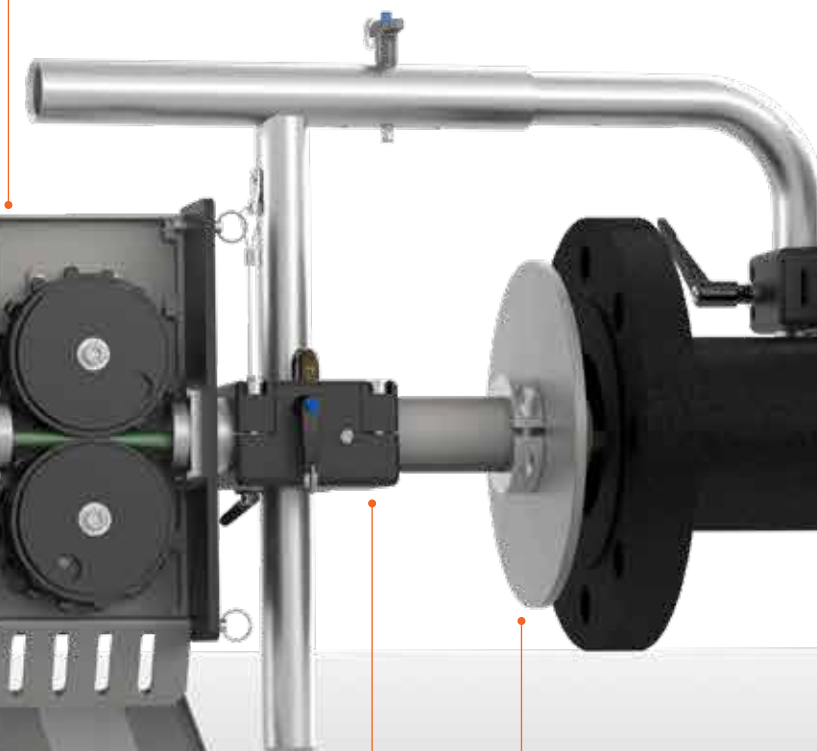

### STRAP MOUNT

Quickly and securely fastens tractor to a wide variety of pipe sizes.

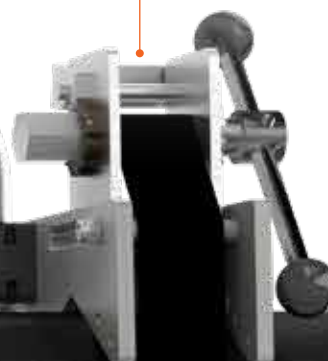

### SPLASH PLATE

Backout prevention for safety and protects tractor from backwash.



### COLLET BLOCK

Safety collets are available for every hose size.

### SUPPLY HOSE

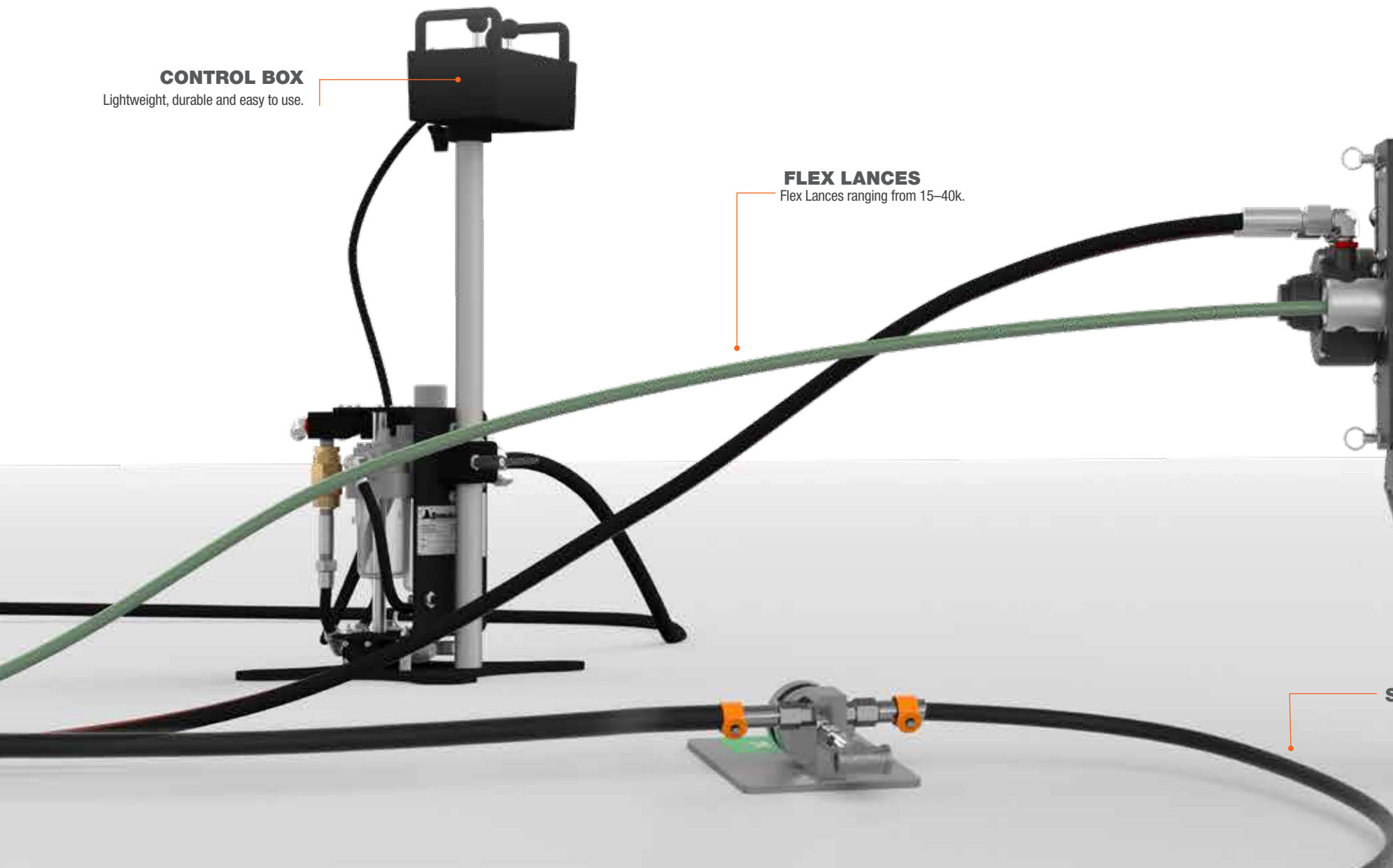

# CUSTOM SOLUTIONS FURNACE & BOILER CLEANING

**CUSTOM SOLUTIONS**

## CABLE SWIVEL TOOL (CST)

The patented CST-AIR has a unique hollow-shaft design allowing it to slide on a 3/8 in. (9.5 mm) diameter stretched cable (not supplied) for cleaning hard to access equipment like furnaces and boilers. The CST uses a separate pulling cable or an Autobox ABX-PRO for propulsion, and head rotation is powered by an air motor.

- ✔ Extension nipples adapt the tool to various vessel sizes and improve jet quality by reducing stand-off distance
- ✔ Ideal for cleaning Direct Fired Furnaces, Superheaters, Economizers, Boilers, Reformers, Cokers and Precipitators

### CST-PRO

Use an AutoBox ABX-PRO tractor to drive the CST and eliminate the need for a pulling cable. The ABX-PRO delivers consistent and remotely adjustable forward and reverse speed for effective cleaning.



### FLEXIBLE 6-PORT HEAD

Configured with 2 ports @ 90°, 2 ports @ 80°, 1 port @ 70° and 1 port @ 110°. Simply select the ports needed for the job and plug the others. Extension nipples further adapt the tool to various vessel sizes and improve jet quality by reducing stand-off distance.



TOOL MODEL	PRESSURE RANGE	FLOW RANGE	INLET CONNECTION	ROTATION SPEED	ROTATION RANGE	WEIGHT
CST-AIR	Up to 10k psi (700 bar)	Up to 170 gpm (640 l/min)	2 x 1" NPT	5-60 rpm	360°	46 lb (21 kg)

## BIG FLOW WATERLANCER (BFW-100)

The BFW-100 is an automated system designed for hands-free online boiler cleaning that enables contractors to reduce down time by cleaning at high temperatures. With a 300 gpm (1140 l/min) flow capability, the BFW-100 can effectively clean any large vessel with limited entry access.

The BFW-100 features an adjustable cart with an air-powered boom positioner and provides excellent cleaning for pulp plant boilers, refinery and chemical plant vessels, as well as furnace radiant sections.

- ✔ Temperature resistant design reduces downtime by allowing cleaning operation while online
- ✔ Remote Control Box controls linear and rotation speeds from a safe distance
- ✔ Adjustable rail and cart allows for easy tool positioning, including elevation and angle of the lance
- ✔ Cantilever option available for lengths up to 24 ft (7.3 m)



### IDEAL FOR:

- ✔ Pulp plant boilers
- ✔ Refinery and chemical plant vessels
- ✔ Furnace radiant sections
- ✔ Boiler floors

TOOL MODEL	PRESSURE RANGE	FLOW RANGE	INLET CONNECTION	ROTATION SPEED	LINEAR SPEED	STROKE LENGTH
BFW-100	10k psi (700 bar)	300 gpm (1140 l/min)	1" NPT	10-50 rpm	8-35 ft/min (2.4-11 m/min)	Up to 24 ft (7.3 m)

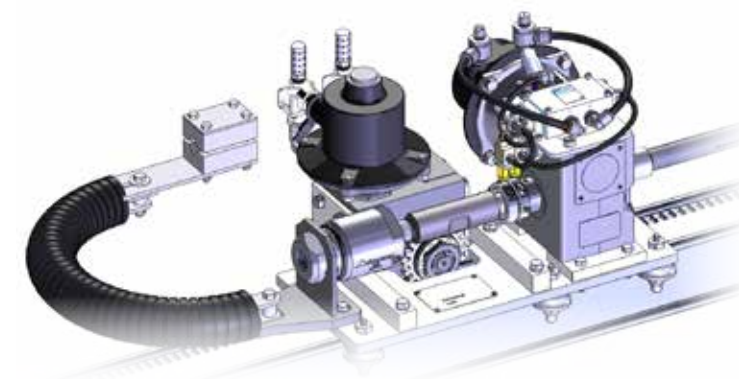

**OPTIONAL GEAR DRIVEN TRACTOR AVAILABLE**

**CAN BE MOUNTED ON EXISTING STANDS IF MOBILE CART IS NOT REQUIRED**

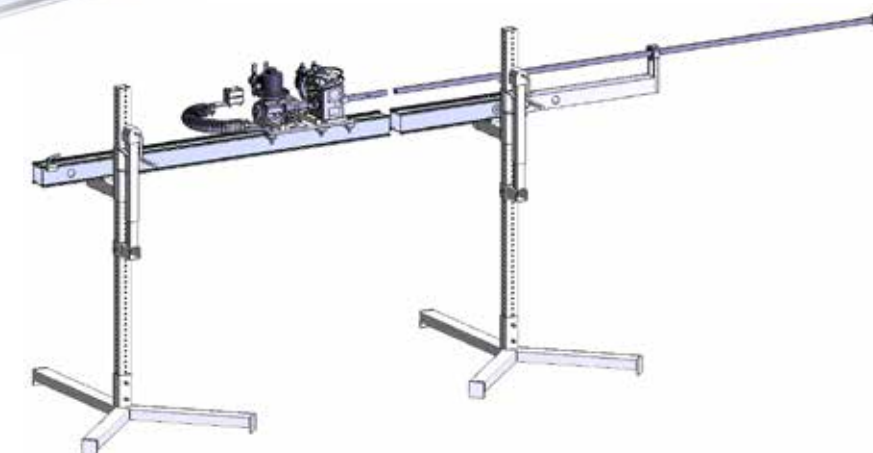



# TANK & VESSEL CLEANING

A full selection of 2D and 3D nozzles, positioning tractors and booms for cleaning tanks and vessels

**LARGE DIAMETER TANKS THAT HAVE AN ACCESSIBLE CENTER OPENING CAN EFFECTIVELY BE CLEANED USING A 2-D ROTATING TOOL THAT IS SLOWLY RAISED OR LOWERED WITH THE ABX-500 TO ACHIEVE COMPLETE COVERAGE. WHEN THIS IS NOT POSSIBLE, DUE TO CENTRAL OBSTRUCTIONS SUCH AS AGITATORS, THE BEST SOLUTION IS TO USE A 3-D TANK CLEANING TOOL AND A POSITIONING BOOM.**



### HOSE TRACTOR

Rugged hose feed tractor for accurate positioning of tank cleaning nozzles.

### 3D TANK CLEANING TOOL

Gearing rotation of body and arms provides complete cleaning coverage of tank surface.

### CONTROL BOX

The control boxes are designed to be durable, lightweight and cross-compatible.

### DUMP VALVE

StoneAge supplies a complete line of Dump Valves ranging from 15-40k.

## AUTO HOSE TRACTOR

- ✓ Remote hose feed tractor increases productivity and reduces operator fatigue
- ✓ Handles hose sizes from 0.56-1.75 in (14-4 mm OD) with no modifications
- ✓ Hose clamp pressure and feed rates can be remotely adjusted
- ✓ Operates in horizontal or vertical position for tank and pipe cleaning
- ✓ Passes hose couplings up to 1.75 in (45 mm OD) for long runs

HOSE SIZE	0.56-1.75 in. 14-45 mm OD
MAX. HOSE CRIMP	1.75 in. 45 mm OD
HOSE FEED RATE	1-30 ft/min 0.3-9.1 m/min
PUSH/PULL FORCE	Up to 200 lbs 90 kg
MAX. AIR PRESSURE	125 psi 0.86 MPa
DIMENSIONS	8.3 x 16.9 x 8.2 in. 211 x 429 x 208 mm
WEIGHT	90 lbs 22 kg

# POSITIONING BOOMS

## POSITIONING BOOMS

Large tanks and vessels can be among the most difficult cleaning challenges due to their size, limited access and internal geometries. We can offer several positioning booms that pair with our 3D tools to clean tanks without requiring operator entry.

The use of a positioning boom allows you to safely place the tool closer to the surface to be cleaned and away from obstructions for optimal results.

## SIMPLE BOOMS

Positioners provide up to 19 ft (5.8 m) of reach for the 3-D tank cleaner in addition to tilt and rotation adjustments. Intended for vertical or near vertical applications.

- ✓ Easily adjustable extension/retraction lengths means the cleaning nozzle can be extended or retracted to a variety of insertion depths for better cleaning coverage
- ✓ 24 in. (610 mm) aluminum mounting plate secures to the vessel during cleaning operation, increasing operator safety
- ✓ Inspection hatch allows for line of sight placement of cleaning head to check cleaning progress
- ✓ Portable and quick setup; since no special tools required to position head

## SIMPLE BOOM SPECIFICATIONS

	SB-H	SB-P16
MAX. PRESSURE	N/A	10k psi (700 bar)
MAX. FLOW	50 gpm (190 l/min)	150 gpm (570 l/min)
INLET CONNECTIONS	1/2" NPT or 1-12 "M"	1" NPT
MAX. HOSE I.D.	0.5 in. (13 mm)	N/A
MAX. END FITTING	1.5 in. (38 mm)	N/A
WEIGHT	80 lb (36 kg)	80 lb (36 kg)

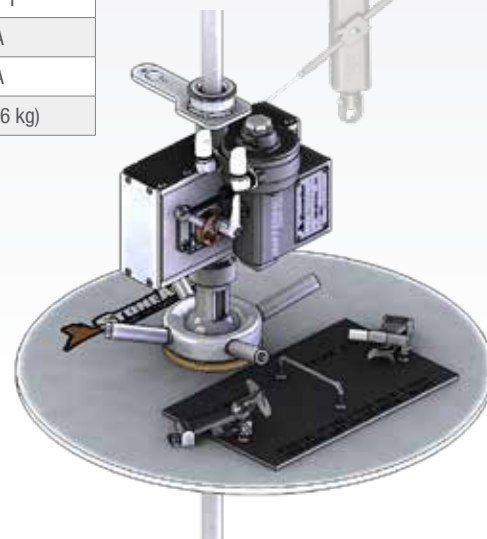
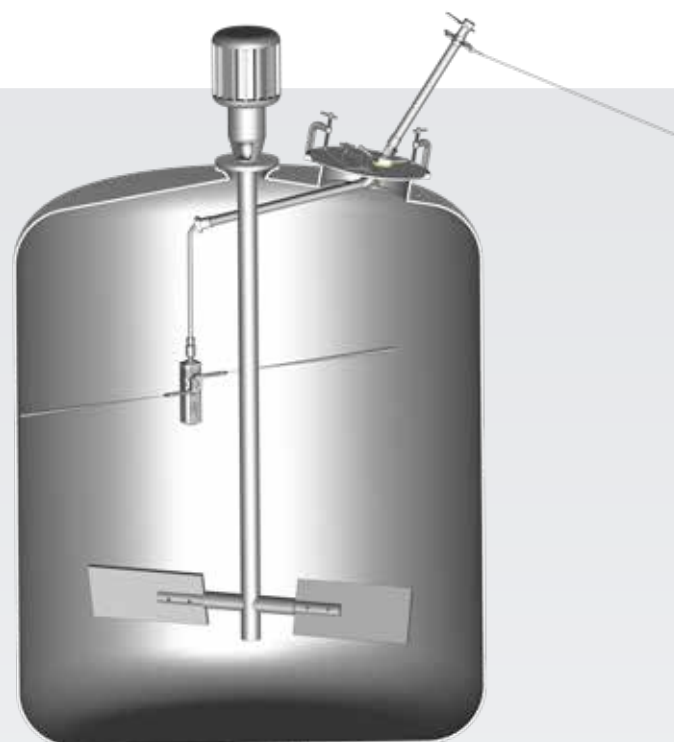

## HANDS-FREE OPTION

Pro-Drive tractor is the simple boom to automate the hose feed for increased safety.

## TELEBOOM

The TeleBoom is designed to hold and position most types of waterblast cleaning nozzles. It is particularly useful for placing rotary nozzle heads inside tanks and vessels. It is intended only for vertical or near vertical applications.

- ✓ Lightweight and compact for portability
- ✓ Three positioning functions: Telescope, Angle and Rotate
- ✓ All of the functions are driven by hand operated wheel cranks
- ✓ Attaches to various size manway openings by means of custom made adapter plates

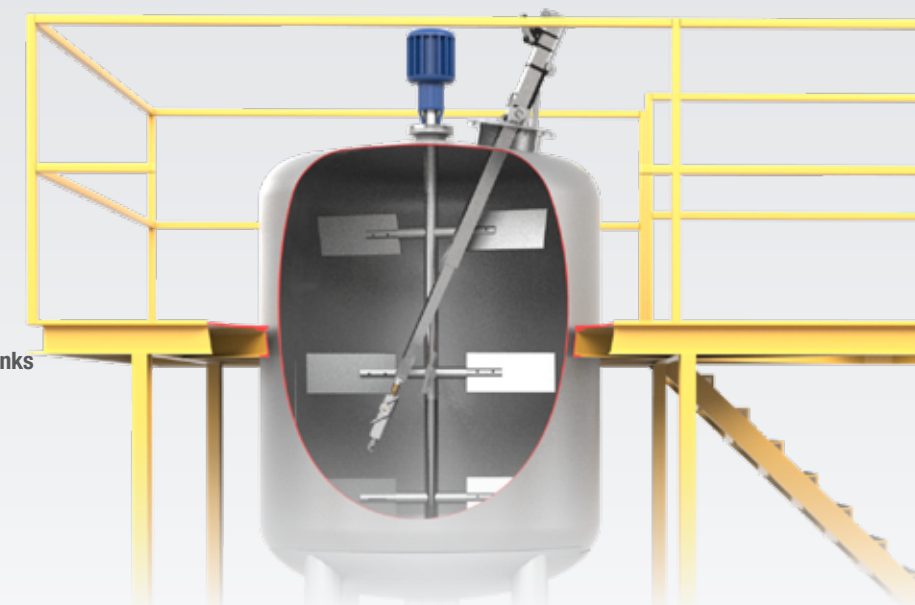

## TELEBOOM SPECIFICATIONS

MODEL	TB-6-TR	TB-8-TR	TB-10-TR
MAX. PRESSURE	22k psi 1500 bar	22k psi 1500 bar	22k psi 1500 bar
MAX. FLOW	100 gpm 380 l/min	100 gpm 380 l/min	100 gpm 380 l/min
INLET CONNECTIONS	3/4" NPT, 3/4" MP or M24	3/4" NPT, 3/4" MP or M24	3/4" NPT, 3/4" MP or M24
MAX. HOSE I.D.	3/4 in. 19 mm	3/4 in. 19 mm	3/4 in. 19 mm
COLLAPSED LENGTH	6.5 ft 2.0 m	8.5 ft 2.6 m	10.5 ft 3.2 m
MAX. REACH	13 ft 4.0 m	19 ft 5.8 m	25 ft 7.6 m
WEIGHT	120 lb 55 kg	130 lb 59 kg	140 lb 63 kg

## EXTENSION BOOM

This Extension Boom allows the operator to raise and lower a 3D tool at different speed rates. The extension boom utilizes a durable rack and pinion drive to position the vertical lance. The lance can be stopped at any height and offers a maximum stroke length of 12 feet, and the mounting flange can be customized to fit your tank opening.

## CONTROL BOX

Control Box which manages the air supply to the boom, controls the vertical position and linear speed of the lance. This Control Box can be modified to fit your specific application.

## EXTENSION BOOM SPECIFICATIONS

	EB-100
MAX. PRESSURE	12k psi (830 bar)
LINEAR SPEED	8-45 in./min (0.2-1.1 m/min)
MAX. STROKE LENGTH	12 ft (3.7 m)
INLET CONNECTION	3/4" NPT

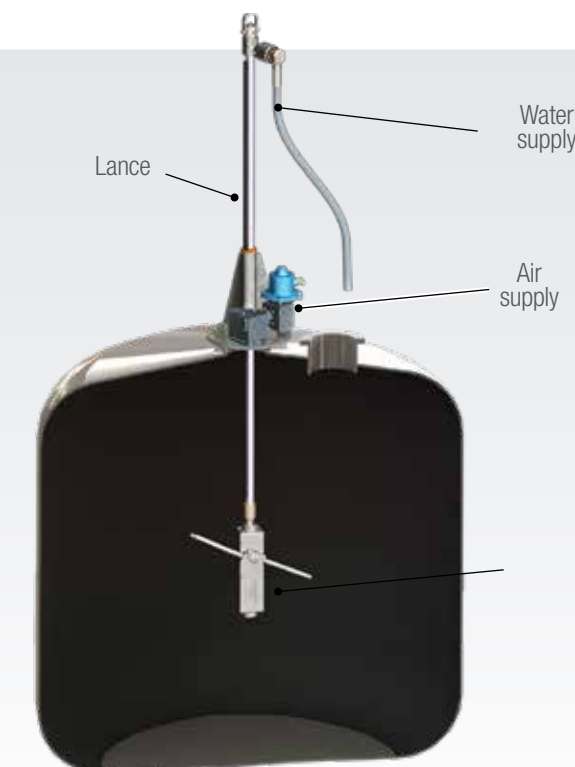

# 3D TANK CLEANING

## BRIO-100

The BRIO-130 is a powerful and highly adaptable 3-D cleaning tool designed to easily adjust to a wide range of pump capacities, working pressures and cleaning applications. The body of the TR-130 rotates in one axis while the arms rotate in another, providing full cleaning coverage of all tank surfaces without requiring operator entry.

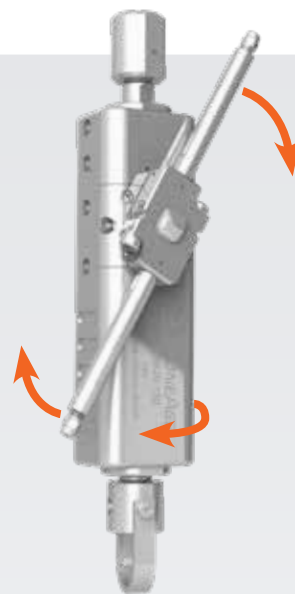

## BRIO - CAGE CENTRALIZER

The BRIO cage-style centralizer. Ideal for applications where debris or internal structures may interfere with the cleaning operation.



## EXTENSION NIPPLES

Includes two standard 8 in. (203 mm) extension nipples. Longer nipples can be used up to 48 in. (1200 mm). Custom lengths are available on request.



<b>PRESSURE RANGE</b>	2–22k psi (138–1500 bar)
<b>FLOW RANGE</b>	10-81 gpm (38-307 l/min)
<b>TOTAL WEIGHT</b>	35 lbs (16 kg)

## BRIO-200

The offered product is the industry's most powerful 3-D tool. It is capable of delivering flows up to 220 gpm (830 l/min) with minimal pressure loss. Applying higher flows allows contractors to remove thicker deposits and deliver longer and harder hitting jets from further distances. Ideal for cleaning hard applications such as large tanks and difficult materials such as coke deposits.

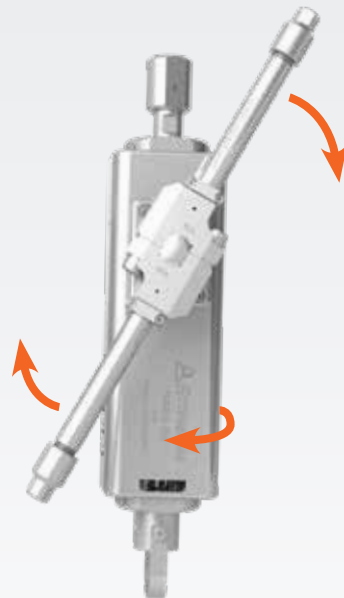

## LIFTING ASSEMBLY

The BRIO-200 comes with a heavy lifting assembly. Includes two quick release pins, two ring attachments and a choice of P16 or MP16 coupling.



<b>PRESSURE RANGE</b>	8–15k psi (550–1000 bar)
<b>FLOW RANGE</b>	50–220 gpm (190–830 l/min)
<b>TOTAL WEIGHT</b>	100 lbs (45 kg)

- ✔ Small entry diameter enables access to more tanks and vessels
- ✔ If the arms hit an internal obstruction while in operation, the Torus simply stops rotating without damaging the gear mechanism
- ✔ Minimal pressure loss which provides more power delivery than other tools on the market
- ✔ Interchangeable manifolds and couplings allow the operator to use the Torus on different pumps ranging from 10k psi (700 bar) to 20k psi (1500 bar)
- ✔ Wide range of accessories are available including positioning devices, cage centralizers and extensions help adapt the Torus to specific needs and jobs

# 2D TANK CLEANING

## BJV

The BJV is our most versatile line of controlled rotary tools. The highly configurable design makes them ideal for cleaning tanks or large pipes. A variety of head and jetting options can be combined with extension arms to easily customize the tool for cleaning large diameter vessels.



- ✔ Easy to pair with Control Box for hands-free tank cleaning
- ✔ Add extension arms to reduce stand off distance in large vessels
- ✔ Can be configured for fast or slow rotation speed depending on the material being cleaned
- ✔ Interchangeable heads allow the tool to be used with any type of pump
- ✔ Simple nozzle changes allow operators to configure for multiple cleaning applications

## EXTENSION ARMS

Add custom length extension arms to reduce stand off distance and deliver maximum cleaning power in any size tank or vessel.



TOOL MODEL	PRESSURE RANGE	FLOW RANGE	ROTATION SPEED	INLET CONNECTION	WEIGHT	MAX. WATER TEMPERATURE
BJVE-P16	2–10k psi (140–700 bar)	20–200 gpm (76–757 l/min)	25–95 rpm (Slow) 50–200 rpm (Medium) 85–300 rpm (Fast)	1" NPT	8.5 lbs (3.9 kg)	160 °F (70 °C)
BJVE-P12	2–15k psi (140–1000 bar)	12–100 gpm (45–380 l/min)	20–95 rpm (Slow) 40–190 (Medium) 70–275 rpm (Fast)	3/4" NPT	8.5 lbs (3.9 kg)	160 °F (70 °C)
BJVE-M24	2–22k psi (140–1500 bar)	12–100 gpm (45–380 l/min)	20–95 rpm (Slow) 40–190 (Medium) 70–275 rpm (Fast)	M24	(8.5 lbs (3.9 kg)	160 °F (70 °C)
BJVE-MP12	2–22k psi (140–1500 bar)	10–60 gpm (38–230 l/min)	20–95 rpm (Slow) 40–190 rpm (Medium) 70–275 rpm (Fast)	3/4" MP	8.5 lbs (3.9 kg)	160 °F (70 °C)
BJV-H9	20–40k psi (1400–2800 bar)	3.4–20 gpm (13–76 l/min)	20–60 rpm (Slow Fluid) 90–250 rpm (Fast Fluid)	9/16" HP	9.3 lbs (4.4 kg)	160 °F (70 °C)

**FOR MORE INFORMATION PLEASE CONTACT YERNUR METAL ||| EXECUTIVE DIRECTOR**

**BR INDUSTRIAL OPERATIONS (BRIO) LLP**

**Tel: +7 (702) 345 07 12**

**E-MAIL: metal@br-industrial.kz**

**WEBSITE: https://www.br-industrial.kz**